CASTLINE SYSTEMS

CABLECALC version 3

FOR WINDOWS



Copyright © 1999 Castline Systems All rights reserved

Microsoft is a registered trademark of Microsoft Corporation.

Windows is a registered trademark of Microsoft Corporation.

All other registered trademarks are acknowledged.

References

Requirements for Electrical Installations IEE Wiring Regulations Sixteenth Edition BS7671 : 1992 Incorporating Amendment No. 1, 1994 (AMD 8536).

IEE Inspection & Testing Guidance Notes 3

Protection Against Electric Shock IEE 16th Edition Wiring Regulations Guidance Notes Number 5 in a series

Castline Systems reserve the right to change specifications without notice.

**Castline Systems,
Welford House, 39 Alfriston Road,
Worthing, West Sussex, BN14 7QS,
United Kingdom.
Telephone 01903 201837**

Contents

Overview	7
About This Reference	7
Use of Cablecalc for Windows	7
About Cablecalc for Windows	7
Getting Started	9
Installation.....	9
Starting Cablecalc.....	9
Windows 95 or 98.....	9
Before you begin	10
Help	10
Starting Cablecalc.....	10
Starting Cablecalc	10
Starting a Calculation	10
Saving Your Work (levels 2-3-4)	11
Setting Your Printer	11
Printing Reports	11
Correcting Calculation Errors	12
Hint Button.....	12
Viewing the sample file	12
Setting up a Project File.....	13
Project Default Values	13
Create Distribution Boards	14
Create Distribution board.....	14
Formulae and Conversion.....	15
The Cable Calculator	17
Tab 1 - Supply	17
To calculate and save a cable	17
Type of Circuit:.....	17
Diversity	19
Tab 2 - Cables	20
Tab 3 - Protection	21
Overload / short circuit protection	21
Type of circuit.....	21
Select Protective Device.....	21
Tab 4 – Derating.....	23
Thermal insulation (Ci)	23
Tab 5 - CPC Details.....	25
Select CPC.....	25

Tab 6 - Calculate	27
Cable Size.....	27
Volt Drop	27
Impedance	28
Calculation related problems	28
1.) Cable Size.....	28
2.) Volt Drop	29
3.) Impedance	29
The Project Manager	31
The Project Manager	31
Buttons	32
Menus.....	33
Projects: A beginners guide.	34
1) Create Project file	35
2) Create Distribution board within the project file.....	35
3) Save a circuit within the Distribution board file.	36
To calculate and save a cable.....	37
To calculate a cable.....	37
To calculate a sub main cable.....	37
Utilities	39
The Time Curve Utility.	39
The menus	39
The Conduit Utility.....	42
The menus	42
The Trunking Utility.....	44
The menus	44
The Diversity Utility.....	45
The menus	46
Trouble Shooting	49
Version.....	49
Where to look for answers	49
Computer Related Problems	49
Operation problems	51
Error codes	51
Glossary of Terms	53

Overview

About This Reference

This reference is a guide to the use of the Cablecalc for Windows programme, and covers the general aspects of operating the various features available. It does not profess to be a *Windows* Tutorial. However, some points essential to the operation of the programme will be covered.

Use of Cablecalc for Windows

Cablecalc for Windows is for use by electrical contractors, electrical engineers and consultants that possess a good general knowledge of the electrical design and installation trade. Many of the terms and descriptions used in Cablecalc for Windows will be very obvious to them, but will be meaningless to any non electrical users of the programme. We must stress that Cablecalc for Windows is not a magic wand for creating electrical design engineers and emphasise that the experience and judgement of the competent electrical engineer conversant with the IEE Wiring Regulations will greatly enhance the use of this programme.

About Cablecalc for Windows

Cablecalc for Windows is designed to produce cable sizing and circuit evaluation data to comply with the IEE Wiring Regulations, Requirements for Electrical Installations (BS 7671 : 1992) incorporating amendment No. 1, 1994 (AMD 8536). Reports may be printed on any printer supported by *Microsoft Windows*, and may also be stored on disc and recalled later for updating (as well as ease of generating file copies for office use).

NOTE: Cablecalc for Windows version 3 levels 2 – 3 & 4 will export circuit data to FormFill for Windows versions 2 and 3.

All software supplied by Castline Systems has been fully checked for all known viruses before dispatch. Please note that all Castline Systems software has the name of the licensed user embedded into the code. Should the software detect that it has been installed incorrectly (or that no company name has been entered) then it will operate in Unregistered Demonstration mode only.

Cablecalc 'Plus' for Windows (level 2) provides an invaluable set of additional utilities offering the following additional features:-

- Time Curve
- Conduit
- Trunking
- Diversity
- Distribution board schedules

- Formulae and conversions
- Lighting circuit calculations
- Busbar trunking calculations

Cablecalc 'Elite' for Windows (level 3) provides the following additional features:-

- Phase balance graphs
- Schematic diagrams
- Circuit charts
- Multiple circuit calculations

Cablecalc 'Professional' for Windows (level 4) provides the following additional features:-

- Single Line Diagrams
- Schematic diagrams
- Cost details

Getting Started

Installation

To **install** Cablecalc for Windows Version 3, place the CD in your CD-ROM drive and click **start**, then **run**, then type **D:\setup** and click **ok**. Cablecalc will be installed to C:\program files\Cablecalc.

It is recommend that your computer is set for a resolution of 1024 x 768 or greater and recommend a minimum requirement of 640 x 480.

Starting Cablecalc

Windows 95 or 98

To run the programme from Windows 95 or Windows 98:

To run the programme from the 'Start' Button

- Click the '**Start**' button
- Select '**programs**'
- Select '**Castline**'.
- Select '**Cablecalc**'.

To run the programme from the Castline Program Group

- Double click on the Cablecalc for Windows icon in the Castline Program Group

It is recommended that the screen resolution be set to 1024 x768. However the programme will work in 640 x 480 but some of the features may appear distorted or may not be accessible on the screen.

The resolution may be changed from the 'Windows Control Panel'

- Click the '**Start**' button
- Select '**Settings**'
- Select '**Control Panel**'
- Select '**Display**'

Before you begin

Help

If you require additional help whilst using Cablecalc for Windows, just press the **F1** key at any time to bring up either a help screen related to the area of the programme that you are using, or the main Cablecalc for Windows help index. To return to the list below after reading each of the items, just click on the **Back** button below the menus. Finally, to exit Help and go back to the programme itself, press **Alt & F4** or click on the **File** menu then choose **Exit**.

Starting Cablecalc

Starting Cablecalc

When you load Cablecalc for Windows, a title screen will be displayed while the main programme is loading. The title screen will then clear to display the 'Cable Calculator' screen

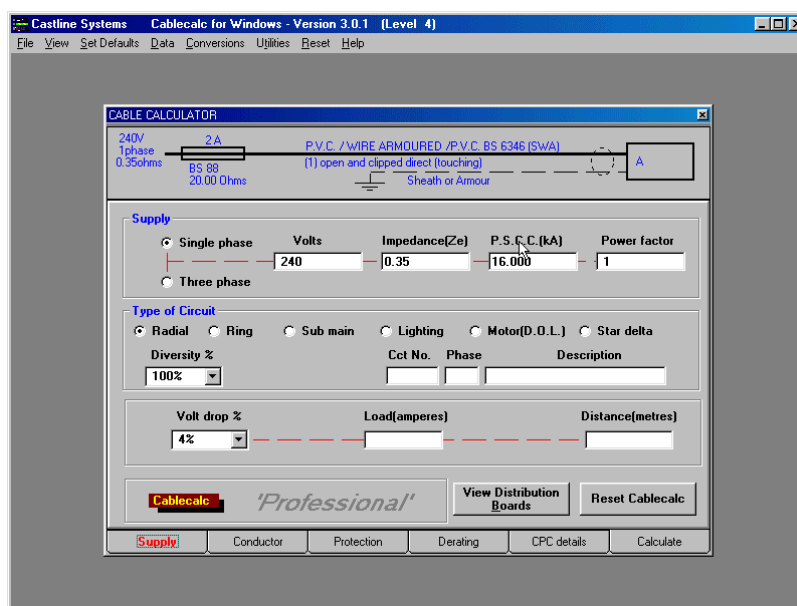

Please note that there is a quick help system built in to the main screen. As the mouse cursor passes over the various controls on the main screen a brief description of their uses is displayed

Starting a Calculation.

In the centre of the screen are the boxes, which allow you to enter the data needed to perform calculations. The default values are already filled in but can be changed, either by over-writing them or by changing the user default settings from the 'Set Defaults' menu.

You will notice that on the lower edge of the Cable Calculator there are Index Tabs. Each of these tabs relates to a section of the current form and most of them will require the input of data. To access the input screen associated with each Tab, click on the tab itself.

Boxes on the forms mainly require either text or a numeric value to be entered into them. If a box has a button with an arrow pointing downward in it attached to it then pressing this button will drop down a list of possible options that can be chosen. To select one of these options just click once on it using the mouse.

NOTE: If there are more options in the list that can be displayed at any one time on the screen, a scroll bar will be shown at the right-hand side of the list.

Small blank square boxes may be selected by clicking on them once with the mouse, and are usually either/or or yes/no choices (e.g. the 'Separate cable' facility in the CPC details section). When you click on this type of box the box will either become checked or will become blank.

Small round boxes surrounded by a frame denote various options, only one of which can be selected at any time (e.g. the Type of Circuit buttons on the Voltage screen).

NOTE: In all cases context-sensitive help about any part of the data entry screens (and the rest of the programme) is available by pressing the **F1** key.

Saving Your Work (levels 2-3-4)

Once you have completed your calculations, the next operation is to print them. However, it is advisable to save them first. This is achieved by choosing **Open/Save File** from the **File** Menu with the mouse or by pressing **Alt & F** together, followed by **O**. See 'Project Manager'

NOTE: You can also re-load this calculation should you need to come back to it at a later date by choosing the **Open Calculation File** option from the **File** menu (Keyboard Shortcut: Press **Alt & F** followed by **O**).

Setting Your Printer

Before printing you may wish to check that the settings for your particular printer are correct. Choosing **Printer Set-up** from the 'File' menu will display the standard *Windows* Printer Control Box and allow you to change any required settings. However, in most cases this should not be necessary. Refer to Printing Reports below as well as the Troubleshooting Guide later in this manual. Please note that the Printout Defaults button allows you to customise the printout to your exact requirements and can add/modify such items as Job Reference, Cable Reference etc. and allow the setting of a top margin so that headed paper can be used.

Printing Reports

To print your Report, choose **Print** from the file menu or press the **Print** button at the bottom of the Calculate screen. The current result will then be printed to the local printer. (Keyboard Shortcut: Press **Alt & F** followed by **P** (For more details on printers and their configuration, refer to the *Microsoft Windows User Guide* supplied with your computer). See also the *Troubleshooting Guide* below. Please note the **Printer Set-up** may be accessed from any of the following methods: -

- a) From the file menu for configuring the printer & paper in use,
- b) Keyboard Shortcut: Press **Alt & F** followed by **R**

- c) Or the button on the Calculate Screen (used for setting various messages as well as the style of type font for the printout).

Print Preview will allow you to see what your printout will look like before actually printing it (see note below). It is available both by pressing the **Print Preview** button on the Calculate screen as well as choosing **Print Preview** from the file menu (Keyboard Shortcut: Press **Alt & F** followed by **V**). To exit from **Print Preview** press **Alt & F4**.

NOTE: Cablecalc for Windows will support colour printers if available and will print using the same colour(s) as displayed on the screen. Also, what you see on the screen in the Print Preview is a representation of what appears on the printer, shown to the correct scale. The printouts will, in nearly all cases, look clearer than this.

Correcting Calculation Errors

If you have an error in a calculation (i.e. a Fail) when you press the **Calculate** button you will see that on the right hand side of the calculation box there are three coloured indicators which show either “PASS” or “FAIL” dependant on the result of the calculation(s). Look at the values associated with whichever indicator(s) that show “FAIL” and one or more of them should be highlighted in RED. This will give you an idea of the cause of the problems with the calculation. Figures 3a & 3b show some examples of this.

Hint Button

If a “FAIL” situation is flagged then the hint button will appear. Clicking on the hint button will reveal some possible explanations and solutions for the calculation failure. To return to the calculation screen click the hint button once more.

Viewing the sample file

We have included a small sample file called Castline. To view this file from the Cable calculator screen click the command button ‘**View Distribution Boards**’ located at the bottom of the Cable Calculator window. This will select the Project Manager, which will display distribution board and circuit details.

To view the different types of schedules and reports that have been included in the sample file, click on the command button ‘**Schedules**’. In the schedule screen you may select six types of schedules and graphs from the menu schedule at the top of the screen. You may move between different distribution boards by selecting from the bottom of the screen. Click ‘**close**’ to return to the programme manager.

Setting up a Project File

To create a new project file for use with Cablecalc, select **Set Up Project** from the **File** menu located on the top menu bar, giving your project a unique name using no more than eight characters. (Note that when entering the name certain reserved characters, e.g. ! " £ \$ % ^ & * () _ ^ | < > # ~ @ ; : ? [] { } . , ' - = cannot be used). You can also set up a new project file from the New Project button on the Project Manager screen. For more information on setting up project files see Projects: a beginners guide.

Project Default Values

Select '**Set Defaults**' from the top menu bar

Or

From the Project Manager select '**Details**' from the top menu bar

This area covers the supply characteristics for the project in question and will be the basis for all of the calculations performed in this project.

The items covered are: -

Supply Voltage

Single phase	e.g. 240
Three phase	e.g. 415
Open Circuit	e.g. 240

Volt Drop

Max permissible	e.g. 4%
-----------------	---------

Supply impedance (Ze)

Ze (SPN)	e.g. .25
Ze (TPN)	e.g. .15

Ambient Temperature

Air	e.g. 30
Ground	e.g. 15
Soil Resistivity	e.g. 1.2

Short Circuit Current

P_{sc} (kA) e.g. 16

Power Factor

P.F. e.g. 1

Supply Details

Supply reference e.g. DB-1
Supply location e.g. Basement
Supply description e.g. Switch room at J. Bloggs & Co.

Supplied from

Supplied from e.g. Source
Supplied from circuit e.g. Main incomer

If you want to revert to the original default values click on **Use Default Values**.

Create Distribution Boards

Create Distribution board

The Cablecalc 'Project Manager' must be displayed on the screen before this can be achieved.

To display the Cablecalc Project Manager if it is not already displayed, click '**View Distribution Boards**' at the bottom of the Cable Calculator screen (Supply Tab)

Or

From the drop down menus on the top bar select '**File**' then '**Open/Save File**'

First select a Project by clicking on a project displayed in the project list

Select '**Distribution Boards**' from the top menu bar and then select '**New Distribution Board**' to display the new distribution board entry dialogue.

Enter the name of the distribution board using less than 20 characters. (Spaces are permitted).

Click **OK** to create the distribution board database file. The new distribution board should now appear in the Distribution Board list.

Any number of Distribution boards may be added to a project file.

NOTE: Distribution boards cannot be re-named once they have been created therefore if you do wish to change the name of a distribution board copy it naming it with the new name and then delete the original.

Formulae and Conversion

This section provides a handy ready reckoner set of information for converting between units as well as providing a simple electrician's calculator.

The Cable Calculator

Tab 1 - Supply

The screenshot displays the 'Supply' tab of the Cablecalc Professional software. At the top, a circuit diagram shows a 231.8V 1-phase supply with a 16A BS 88 fuse, connected to a 20m P.V.C. / WIRE ARMoured / P.V.C. BS 6346 (SWA) cable. The cable impedance is 1.184 ohms, and the load is 11A. Below the diagram, the 'Supply' section has 'Single phase' selected, with input fields for Volts (231.8), Impedance (1.184), P.S.C.C. (0.59), and Power factor (1). The 'Type of Circuit' section has 'Radial' selected, with 'Diversity %' set to 100%, 'Cct No.' set to 1, 'Phase' set to R, and 'Description' set to 'Lighting 1'. The bottom section shows 'Volt drop %' set to 4%, 'Load (amperes)' set to 11, and 'Distance (metres)' set to 20. Buttons for 'View Distribution Boards' and 'Reset Cablecalc' are present. The bottom navigation bar includes 'Supply', 'Conductor', 'Protection', 'Derating', 'CPC details', and 'Calculate'.

This area covers the supply characteristics for the circuit in question and most of the inputs can be pre-set using the **User defaults** set up facility from the '**Set Defaults**' menu (Voltage, Ze, PSSC, Pf and Volt drop). The main user inputs are for the selection of the type of circuit; the Load input (Amperes) and the Length of the circuit (metres).

To calculate and save a cable

To calculate a cable, first select the appropriate distribution board from the list in the 'project manager'. This will then load the supply characteristics for that distribution board in to the cable calculator, in the cable calculator window. Fill in the circuit number, phase and description boxes and then proceed with your calculation as normal then click '**save**' on completion. Confirm details in the '**save circuit**' screen and click **ok**.

Type of Circuit:

Radial circuit

This is the default option and is for a category 1 circuits

Radial circuits are conventional circuits feeding socket outlets, lights etc.

Ring circuit

Ring final circuits are circuits arranged in the form of a ring and connected to a single point of supply.

This option requires input for the distance (metres). The Load input box will be disabled, as the load for the calculation of voltage drop for the circuit is taken as 25% of the protective device rating.

NOTE: The Distance input for a *ring circuit* is to the half way point of the circuit or the distance to the furthest socket outlet, not the total length of the cable from the protective device and then back again.

NOTE: Ring circuit. The Load input box will be disabled, as the load for the calculation of voltage drop for the circuit is taken as 25% of the protective device rating.

Sub main

Circuits feeding distribution boards.

To calculate a sub main cable: From the ‘project manager’, select the distribution board that the cable is coming from, then on the cable calculator screen select ‘**sub main**’ and then select three phase if relevant. A yellow grid should now be visible. In the left column of the grid add the load in amperes, in the middle column the distance in metres, then when you click to the right column a drop down list will appear, select the relevant distribution board that the cable is feeding. If your sub main cable is looping to more than one distribution board then complete section two as appropriate. Click **ok** and then go back to the cable calculator screen and continue as normal. Another yellow grid will appear displaying the result of the sub main(s), click ok to continue, and then click on ‘save’.

Lighting circuit

This option is for category 1 circuits that are looped together e.g. street lighting installations, three plate lighting installations and sub mains. Each section of the circuit requires the load at that point and the distance for that section of the circuit. Totals for the entire circuit are displayed at the bottom of the input form and calculated as the cursor moves to the next position.

Star Delta circuit

This option is for a category 1 star delta circuits and requires the distance from the starter to the motor and the full load current for the motor. The root three load is displayed in a separate text box and is the load that will be carried by each of the six conductors in the cable(s).

Motor

Circuits feeding motors.

Diversity

Diversity may be applied to the circuits, anything between 5% and 100% in steps of 5%, with 100% representing the full load. For more information regarding Diversity see the I.E.E. On Site Guide appendix 1 Maximum Demand and Diversity.

NOTE: the input is not accepted until the cursor is moved down and is clear of the last input.

Tab 2 - Cables

231.8V
1phase
1.184ohms

16A
BS 88
4.3636 Ohms

20m
P.V.C. / WIRE ARMoured / P.V.C. BS 6346 (SWA)
(1) open and clipped direct (touching)
Seperate cable

11A

Conductor

Copper
 Aluminium

Type

Cable Flexible cable
 Flex Busbar trunking

Insulation

PVC Rubber
 xlpe/lsf micc

Cable Type

P.V.C. / WIRE ARMoured / P.V.C. BS 6346 (SWA)
P.V.C. SINGLES BS 6004 BS 6231 BS 6346 (6491x)
P.V.C. TWIN AND EARTH BS 6346 (6242y)
P.V.C. / P.V.C. SINGLE CORE BS 6004 (6181y)
P.V.C. SPLIT CONCENTRIC BS 4553
P.V.C. C.N.E. CONCENTRIC ESI 09-7
P.V.C./S.W.A./P.V.C. BC 295 (60% conductance M & Q)

Installation method

(1) open and clipped direct (touching)
(1) open and clipped direct (spaced)
(1) embedded in building materials
(2) direct buried in ground
(16) in ducts or voids
(11) perforated cable tray (touching)
(11) perforated cable tray (spaced)

Cores

2

Size (mm²)

Calculate

Parallel cables

1

Supply **Conductor** Protection Derating CPC details Calculate

This area covers the cables available and there are no user defaults available. Cable parameters should be selected in the following order

Conductor

Type

Insulation

Cable Type

Installation method

Cores

Size/Calculate

Parallel cables

Selecting **Calculate** will calculate the minimum size of cable suitable for the circuit, selecting an actual cable size from the drop down list will evaluate the circuit based on the size of cable selected.

Tab 3 - Protection

231.8V
1phase
1.184ohms

16A
BS 88
4.3636 Ohms

20m
P.V.C. / WIRE ARMoured / P.V.C. BS 6346 (SWA)
(T) open and clipped direct (touching)
Sheath or Armour

11A

Overload / short circuit protection

Overload and short circuit protection Short circuit protection only

Type of circuit

Fixed equipment Socket outlets (domestic and industrial)
 Socket outlets (construction sites) Socket outlets (agricultural premises)

Maximum permissible disconnection time = 5.0 seconds

Select protective device

- Type D Miniature Circuit Breaker
- CARTRIDGE FUSE TO BS 88**
- CARTRIDGE FUSE TO BS 1361
- REWIREABLE FUSE TO BS 3036
- MOULDED CASE CIRCUIT BREAKER BS 3871
- AIR CIRCUIT BREAKER TO BS 3871

Protective device rating

Rating (Amperes) Max Zs (ohms)

16 4.3636

Supply Conductor **Protection** Derating CPC details Calculate

Overload / short circuit protection

Select either overload and short circuit protection or Short circuit protection only.

See regs 473-01 and appendix 4 sections 4 & 5 for details

Type of circuit

Select the type of circuit from the options in this section (Fixed equipment / Socket outlets), the maximum permissible disconnection time will be displayed for the option selected.

Maximum disconnection time permitted.

Fixed equipment **5.0 secs.**

Socket Outlets **0.4 secs.**

Socket outlets special locations **0.2 secs.**

See On Site Guide Section 3.5 - Disconnection Times.

Select Protective Device

This area covers the Protective devices available; there are no user defaults available. Parameters may be selected in any order. The system default protective device type is the BS 88 Cartridge fuse, this was chosen as the system default because it contains the greatest range of current ratings (2-800 A). *Cablecalc for Windows* will automatically select the lowest protective device size greater or equal to the load for the circuit. To increase or decrease the protective device rating click on the arrows below the Rating (Amperes) display window (left arrow to decrease, right arrow to increase). If the protective device rating selected is lower than the load for the circuit then the colour of the display will change from black to red.

The Max Zs (ohms) window displayed is the impedance value for the protective device selected.

NOTE: The total impedance for the circuit (including the external impedance) must not exceed this value or else a fail situation will arise.

The Multiplier display shows the figure that is multiplied to the protective device rating to provide the tripping current, and is used in the following formulae to obtain the protective device impedance (Zs): -

$$\text{Open circuit volts} / \text{Protective device rating} \times \text{multiplier}$$

Multipliers for miniature circuit breakers used in Cablecalc for Windows are as follows: -

Type 1	4
Type 2	7
Type 3	10
Type 4	50
Type B	5
Type C	10
Type D	50

Example: type 2 mcb - 10ampere - 240V open circuit voltage

$$240 / 10 \times 7 = 3.428 \text{ ohms}$$

Magnetic Setting window (ACBs and MCCBs only) use the control below this window to adjust the setting of the circuit breaker (left arrow to decrease, right arrow to increase).

Tab 4 – Derating

The screenshot shows the 'Derating' tab of the Cablecalc software. It contains several input fields and buttons:

- Temperature (Ca) Table 4C1:** Temp [°C] dropdown set to 25, Factor text box set to 1.03.
- Grouping (Cg) Table 4B1:** No. cables dropdown set to 1, Factor text box set to 1.
- Thermal insulation (Ci) Table 52A:** Length (mm) dropdown set to 0 mm, Factor text box set to 1.0.
- Fuse (Cf):** Factor text box set to 1.
- Correction Factor (Ct):** Total correction factor (Ct) text box set to 1.03.
- Calculation method:** Two radio buttons: 'Use worst case only' (unselected) and 'Calculate using all factors' (selected).
- Navigation buttons:** Supply, Conductor, Protection, Derating (highlighted in red), CPC details, Calculate.

This area covers the derating factors that will affect some of the characteristics for the cable selected, these include: -

- the effective current rating,
- the operating temperature,
- the millivolt drop per metre.

Temperature (Ca)

From the drop down list select the ambient air temperature applicable for the circuit, the correction factor for the selected temperature is displayed in the adjacent text box. User pre-set available

NOTE: The Temperature for direct buried cables and cables in ducts is based on a ground temperature of 15°C, the temperature for all other cables is based on an ambient temperature of 30°C.

Grouping (Cg)

From the drop down list, select the number of circuits or multicore cables grouped with this circuit, the correction factor for the selected number of cables is displayed in the adjacent text box.

NOTE: If due to known operating conditions, a cable is expected to carry not more than 30% of its grouped current rating, it may be ignored for the purpose of obtaining the rating for the rest of the group. See regs appendix 4 tables 4B1, 4B2 & 4B3 for details.

Thermal insulation (Ci)

From the drop down list, select the length of thermal insulation as appropriate, the correction factor for the selected length of thermal insulation selected is displayed in the adjacent text box.

NOTE: See regulation 523-04 & table 52A for details.

Fuse (Cf)

The correction factor for the protective device selected will be displayed. If a rewirable fuse to BS 3036 has been selected then a factor of 0.725 will be displayed; all other protective devices will display a factor of 1.

Correction Factor (Ct)

The total correction factor for the circuit will appear in this text box; this factor will be applied to the tabulated current rating for the cable.

Calculation method

The Use worst case only option will apply the lowest of all the correction factors.

NOTE: This is not the recommended method of calculating the correction factor and should be used with caution.

The Calculate using all factors option (standard method) will apply the sum of all the correction factors to the tabulated current rating for the cable.

NOTE: See appendix 4 for details.

Tab 5 - CPC Details

This area covers the circuit protective device (cpc) options and contains three tabulated sections

The screenshot shows a software window titled 'Select cpc'. It contains several checkboxes and radio buttons. The 'Sheath or Armour' checkbox is checked. The 'Conduit' checkbox is unchecked. The 'Internal core' checkbox is unchecked. The 'Trunking' checkbox is unchecked. Under the 'Seperate cable' section, the 'Calculate size (Table 54G)' radio button is selected. Other radio buttons include 'Use same size as cable', 'Calculate size (min)', and 'Select size'. At the bottom of the window, there is a navigation bar with tabs: 'Supply', 'Conductor', 'Protection', 'Derating', 'CPC details' (highlighted in red), and 'Calculate'.

Select CPC

Various options are available for the selection of the cpc for the cable (you may select more than one option) and include: -

Sheath or Armour

Internal core

Conduit

This section displays a list containing light duty and heavy-duty conduit sizes from 16mm up to 32mm. If Steel conduit is selected then the conduit resistance may be included in the earth calculation.

Trunking

This section displays a list containing trunking sizes from 50mm x 50mm up to 300mm x 150mm. If Steel trunking is selected then the resistance of the trunking may be included in the earth calculation.

Seperate cable

This option if selected displays four methods for adding a separate cpc: -

The default is to calculate the size in accordance with Table 54G

Use same size as cable

This will add a separate cpc to the calculation that is the same size as the cable under evaluation.

Calculate size

This will calculate the size of a separate cpc up to a maximum size of 1000mm²

Select size

This option will display a drop down list box containing cpc sizes from 1.0mm² to 1000mm² select the desired size from the list.

Tab 6 - Calculate

231.8V 1phase 1.184ohms	16A	1.5mm ² P.V.C. / WIRE ARMoured /P.V.C. BS 6346 (SWA) (1) open and clipped direct (touching)	20m	226.09 V
	BS 88 4.3636 Ohms 0.09secs		Seperate cable	11A
Cable Size				
1	1.5mm ²	2c	P.V.C. / WIRE ARMoured /P.V.C. BS 6346 (SWA)	20m PASS
◀▶		231.8	Volts	1 phase
▶◀		11	Amperes	Load
Tabulated current rating		21	Amperes	Effective current rating
		21.63	Amperes	
Volt drop				
Voltdrop =		5.71	Volts	2.37 %
corrected mV/A/mtr =		25.9	mV/A/mtr	(tables)= 29
Permitted V.D.=		9.27	Volts	4 % PASS
R1 0.25994 PSCC (circuit) 247.694 Zsc (origin) 0.39288 PASS				
R2 0.13273 Withstand time 0.485se Zsc (circuit) 0.91277				
R1+R2 0.39268 Discon' time 0.09sec Earth Fault Current 147.017				
Zs 1.57668 cpc size 1.5mm ²				
Save		Printout Defaults		Print Preview
				Print
Supply	Conductor	Protection	Derating	CPC details Calculate

This area displays a summary of the calculation/evaluation and is divided into three logical sections providing a pass/fail flag for each section. For more information see [Calculation Related Problems](#) and [Correcting Calculation Errors](#) elsewhere in this manual. At the bottom of this section are buttons to **Save**, **Printout Defaults**, **Print Preview** and **Print**, these items are described elsewhere in this manual.

Cable Size

This section displays the cable size, the number of cables in parallel, the length of the circuit, a description of the cable, the voltage and phase details and the tabulated and effective ratings of the cable. To increase/decrease the cable size or add/subtract cables in parallel, click on the arrows below the relevant items.

Volt Drop

The calculated volt drop and the permitted volt drop for the circuit is displayed both in volts and as a percentage of the line voltage. The millivolts per Ampere per metre (mV/A/mtr), and the corrected mV/A/mtr are also displayed. The Tabulated values of (mV/A/mtr) are the values taken from the tables in the IEE regulations, or alternatively from cable manufacturers data sheets. The corrected values are the tabulated mV/A/mtr values with correction for operating temperature applied. The volt drop calculation is based on the corrected value.

Impedance

This section displays the following information: -

R1

R2

R1+R2

Zs

PSCC

Withstand time

cpc size

Zsc (origin)

Zsc (circuit)

Earth Fault Current

Calculation related problems

Calculation problems are highlighted within the calculate screen by FAIL flags and the relevant item(s) displayed with a red background. These will be in the following areas:

1.) Cable Size

A fail situation here could be caused by: -

Problem Effective current rating highlighted. The load exceeds the effective current rating of the cable

Suggestion *Increase the cable size.*

Suggestion *Add an additional cable in parallel.*

Suggestion *Check that the derating factors are correct especially the factor for grouping as in some circumstances this may be ignored (see regulations appendix 4 notes to table 4B2).*

Problem Load highlighted. The effective current rating of the cable is less than the rating of the protective device.

Suggestion *Increase the protective device size (the protective device rating is displayed red if the value is too low).*

2.) Volt Drop

A fail situation here could be caused by: -

Problem Volt Drop highlighted The calculated volt drop exceeds the maximum permitted volt drop.

Suggestion *Increase the cable size*

Suggestion *Add an additional cable in parallel.*

3.) Impedance

A fail situation here could be caused by: -

Problem Z_s highlighted. The cable/cpc Z_s value is greater than the protective device Z_s value

Suggestion *Increase the cable size*

Suggestion *decrease the protective device size*

Suggestion *Increase the cpc size*

Suggestion *Add a separate cpc*

Suggestion *Check that the supply impedance(Z_e) is correct, (the impedance of the cable/cpc is added to the Z_e, this total must be less than the Z_s value of the protective device).*

Problem R₂ highlighted. There is no cpc present.

Suggestion *Add a cpc*

The Hint button will offer some suggestions for 'Fail' situations.

The Project Manager

The Project Manager

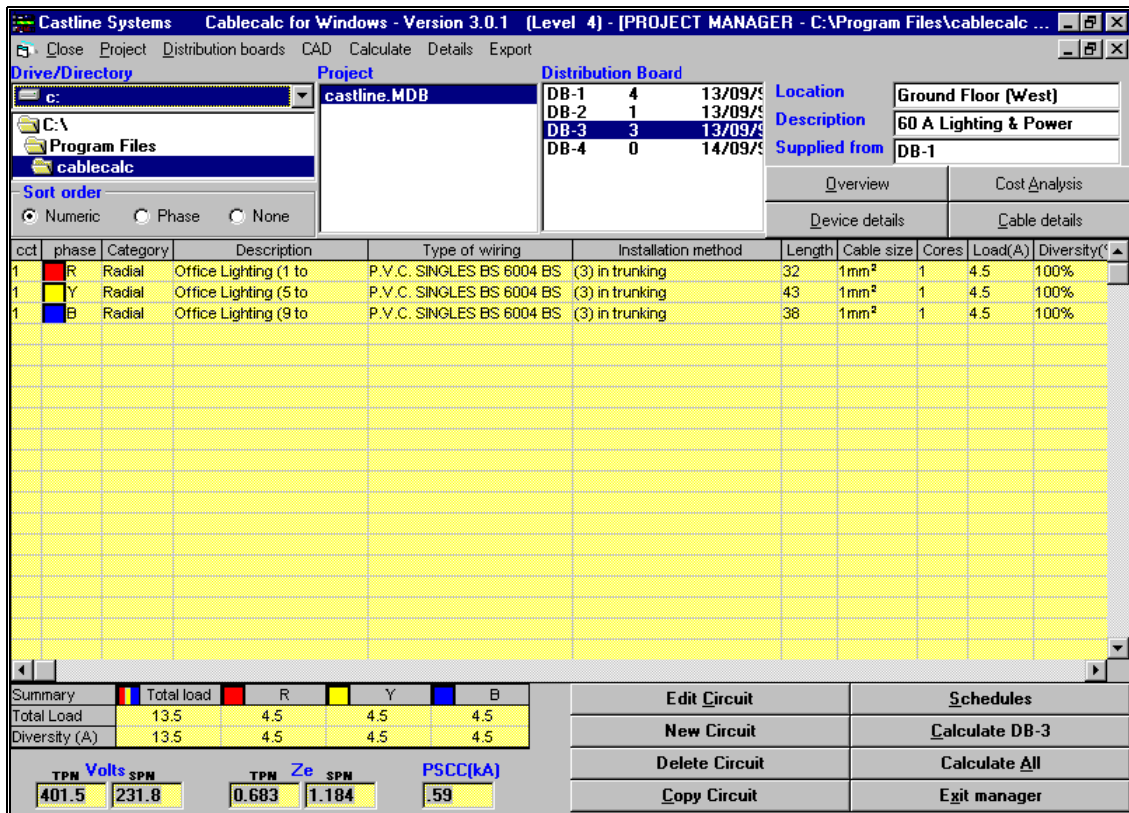

The Project manager is the heart of the Cablecalc programme. It is from the Project manager that projects can be created and distribution boards added and circuits edited or recalculated.

Projects may be selected using the Project dialogue box together with the Drive and Directory lists located at the top of the 'Project Manager'.

Circuit sort order may be displayed in three different ways by selecting either 'Numeric' 'Phase' or 'None' from the 'Sort order' section.

The circuit grid details may be changed using the 'Overview' 'Device Details' 'Cable Details' 'Cost Analysis' buttons (Level 4 only).

The 'Summary' section provides totals for either the design Amperes or the Diversified Amperes (The circuit design loads multiplied by the diversity factors).

The Voltage Impedance and Fault current for the board is displayed at the bottom left of the 'Project Manager'.

Buttons

Edit Circuit

Select a circuit from the grid by clicking on any grid cell and then click the '**Edit Circuit**' button to reload the calculation.

New Circuit

Click the '**New Circuit**' button to reload the 'Cable Calculator'.

Delete Circuit

Select a circuit from the grid by clicking on any grid cell and then click the '**Delete Circuit**' button to delete a circuit.

Copy Circuit

Select a circuit from the grid by clicking on any grid cell and then click the '**Copy Circuit**' button to copy the circuit.

Schedules

This will load the 'Report' section of Cablecalc

Calculate ***

Click this button to recalculate all of the circuits in the distribution board.

Calculate All

Click this button to recalculate all of the circuits in the all of the distribution boards in the project.

Exit Manager

Return to the 'Cable Calculator'.

Overview

Click this button display the default calculation results for the currently loaded distribution board.

Cost Analysis

Click this button display the costs currently loaded distribution board. (Level 4 only).

Device Details

Click this button display the protective device details for the currently loaded distribution board.

Cable Details

Click this button display the cable details for the currently loaded distribution board.

Menus

Close

This will return to the 'Cable Calculator'

Project

<u>New Project</u>	Create a new project
<u>Copy Project</u>	Create a new project
<u>Delete Project</u>	Create a new project

Distribution Boards

<u>New Distribution Board</u>	Add a new Distribution board
<u>Copy Distribution Board</u>	Copy an existing Distribution board
<u>Delete Distribution Board</u>	Delete an existing Distribution board

CAD

Display the Drawing Utility (Level 4 only).

Calculate

<u>Calculate This Distribution Board</u>	Select this menu to recalculate all of the circuits in the distribution board.
<u>Calculate All</u>	Select this menu to recalculate all of the circuits in the entire project.

Details

Click this button display the cable details for the currently loaded distribution board.

Export

Click this button display the cable details for the currently loaded distribution board.

Projects: A beginners guide.

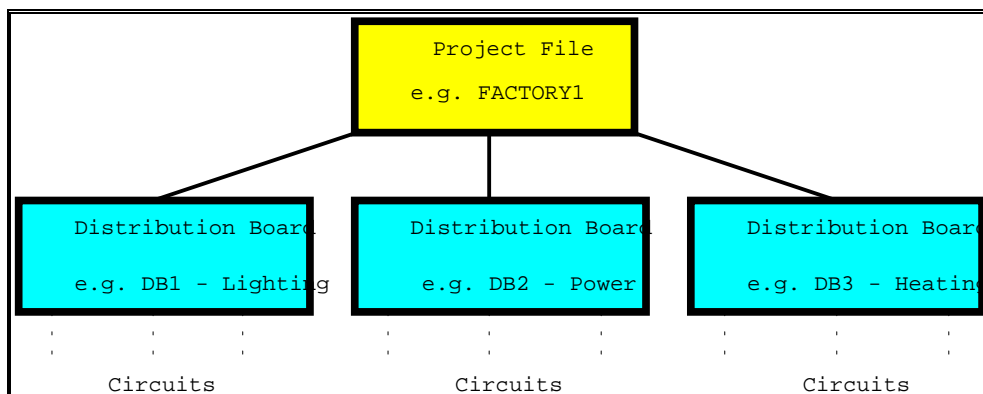

As you can see from the above diagram, a project file contains all the elements of the job. Please note that calculations can not be saved until a suitable distribution board file has been set up and loaded.

A project file is the container file for any number of distribution board files

A project file name must not consist of any reserved characters or use any spaces (see Setting up a Project).

A Distribution Board file is the container file for saving calculation results (circuits).

A Distribution Board file name may be more than eight characters in length and may contain spaces.

A circuit file may only be saved to a Distribution Board file.

A circuit file **must** contain a circuit reference number e.g. 5 and a valid phase reference colour e.g. RYB (you will be prompted for this information when click on the “Save Circuit” button in the “Project Manager” form). Valid phase references are: - R Y B and RYB.

1) Create Project file

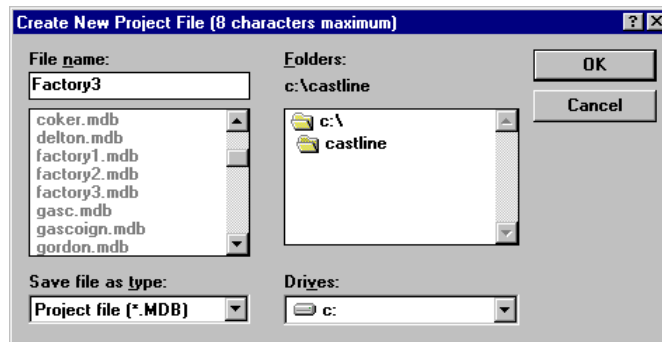

A project file may be created either from the Cablecalc Project manager or from the New Project Dialog box.

- a) To create a Project file from the New Project Dialogue box, from the File Menu select **Set Up Project**.
- b) To create a Project File from the Cablecalc Project manager, from the File menu select **Open/Save File** to display the Cablecalc Project manager. Click on the **New Project** button to display the New Project Dialog box.

In the text box marked **File Name** enter the name of the new project (using no more than 8 characters) e.g. Factory1 and then click **OK**.

2) Create Distribution board within the project file.

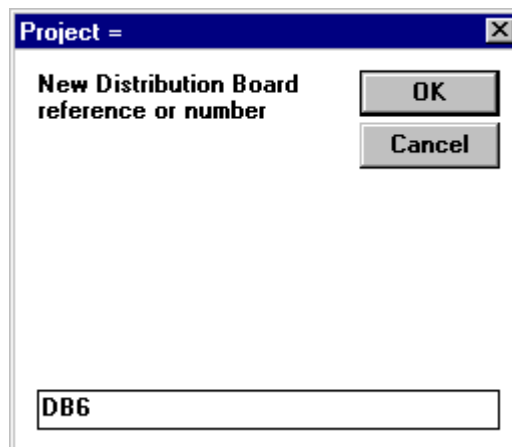

The Cablecalc Project manager must be displayed on the screen before this can be achieved. To display the Cablecalc project manager from the **File** menu select **Open/Save File**.

First select a Project by clicking on a project displayed in the project list. Click on the button marked **New Dis'Board** to display the new distribution board entry dialogue. Enter the name of the distribution board using less than twenty characters. (Spaces are permitted).

Click **OK** to create the distribution board database file. The new distribution board should now appear in the Distribution Board list.

Any number of Distribution boards may be added to a project file.

3) Save a circuit within the Distribution board file.

If you have just performed a calculation then you may save the calculation results by clicking on the **Save Circuit** button.

You will be asked for the following details:-

Circuit Number	e.g.	6
Phase	e.g.	R
Description	e.g.	Office 1 Lighting
Installation method	e.g.	PVC in conduit

Click **OK** to save the data.

If you want to save data for a circuit from scratch without performing a calculation (Inspection and testing) then this can be done by clicking on the **Edit circuit** button.

Before the main circuit database entry screen appears a message with a reminder to click the **add circuit** button before adding a new circuit will be displayed. What this means is that before filling in all the data for a new circuit you must first establish the new circuit in the database, if this is not done then the new data will not be saved. This needs to be done for each **NEW** circuit that you add. Once the circuit has been established you will not need to use the **Add Circuit** button again for that same circuit.

Any number of circuits may be added to a distribution board file.

Click on the '**load circuit**' button to continue.

To calculate and save a cable

To calculate a cable

First select the appropriate distribution board from the list in the 'project manager'. This will then load the supply characteristics for that distribution board in to the cable calculator, in the cable calculator window. Fill in the circuit number, phase and description boxes and then proceed with your calculation as normal then click '**save**' on completion. Confirm details in the '**save circuit**' screen and click **ok**.

To calculate a sub main cable.

From the 'Project Manager', select the distribution board that the cable is coming from, then on the cable calculator screen select '**sub main**' and then select three phase if relevant. A yellow grid should now be visible. In the left column of the grid add the load in amperes, in the middle column the distance in metres, then when you click to the right column a drop down list will appear, select the relevant distribution board that the cable is feeding. If your sub main cable is looping to more than one distribution board then complete section two as appropriate. Click **ok** and then go back to the cable calculator screen and continue as normal. Another yellow grid will appear displaying the result of the sub main(s), click **ok** to continue, and then click on '**save**'.

Utilities

The Time Curve Utility.

The Cablecalc “Plus” for Windows Time/Current curve utility has been developed to produce graphs for displaying protective device time/current characteristics for a large number of commonly used fuses and circuit breakers.

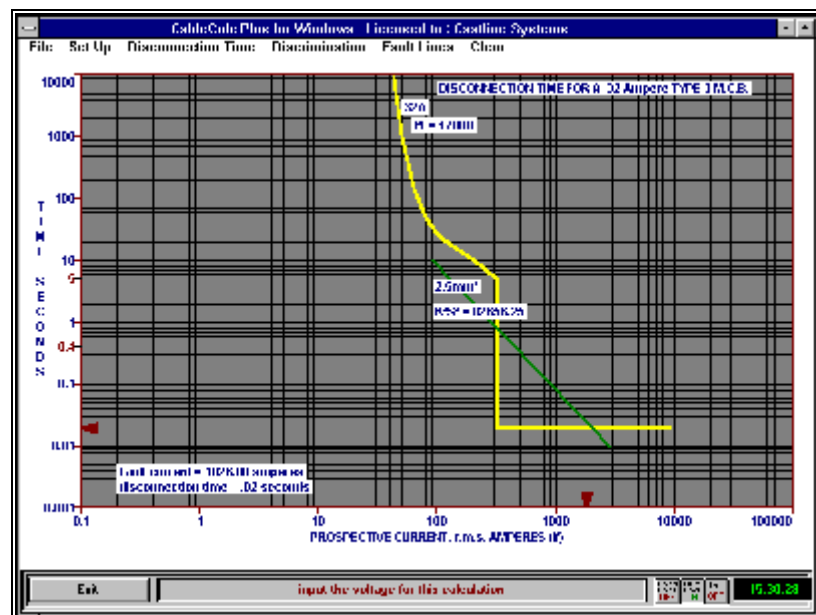

The menus

File

Save to File

Enables the displayed graph to be saved as a bitmap image (*.bmp). Select this option if you intend to add the graph to a document created in any other Windows programme. Once created and then exported to a Windows desktop publishing or Word-processing programme the bitmap images may be sized as required.

Print Graph

This will send a copy of the displayed graph to the local printer. If your printer is a colour printer then the print will be in colour. **Note:** Beware of using dark background colours when using ink jet printers as this will tend to make the graph lines merge into the background resulting in a messy print out.

Exit

Exits Time Curve and returns to the main Cablecalc for Windows screen.

Set Up Colours

Select the screen colours for: -

- Graph background
- Graph border
- Graph curve lines
- Graph log-log lines
- Graph text
- Graph time indication

Three buttons are displayed at the bottom of this form and are as follows: -

OK

This will save the colours that you have selected

Cancel

This will quit the Colour set up option without saving the changes

Set default

This will reset the screen colours to the default colour scheme.

Disconnection Time

This will enable the user to produce a graph displaying an accurate assessment of disconnection time or operating time for a protective device.

Disconnection time or operating time is the time taken from the commencement of a current large enough to cause the fuse elements to melt (or in the case of a circuit breaker, the mechanical contacts to separate), through to the breaking of the circuit. The protective device must be capable of breaking the circuit before any overload current (If) can cause a rise in temperature which may damage the current carrying conductor or any of its associated equipment.

- 1) Select **Disconnection Time** from the menu to reveal the data input screen.
- 2) Select the type of protective device from the **Select protective device** list.
- 3) Select the Rating of the protective device by clicking on the up and down arrows.
- 4) Input the Fault current in Amperes, (this will automatically display the Fault current from the last calculation performed in Cablecalc for Windows)
- 5) Select **continue** to calculate and view the results on screen.

Discrimination

Discrimination of a protective device is the requirement to co-ordinate overload and short circuit protection by assessing the characteristics of the devices used so that energy let through by one device does not exceed that of any upstream protective device or devices. The total I^2t let through energy of the smaller device should not exceed or be too close to the prearcing value of the next larger device. If it is larger then the larger device could operate before the smaller device.

To illustrate this situation Cablecalc “Plus” Time / Curve will allow any number of protective devices to be displayed at any one time. As a general rule, if the curve of a device touches or overlaps that of any other device then discrimination is not achieved and the larger device could be the first to fail.

- 1) Select **Discrimination**, and then select **Add Protective Device** from the menu to reveal the data input screen.
- 2) Select the type of protective device from the **Select protective device** list.
- 3) Select the Rating of the protective device by clicking on the up and down arrows.
- 4) Select **continue** to display the protective device characteristics on screen.
- 5) Repeat as required.

Fault Lines

A conductor fault line is a line plotted against a graph showing the maximum fault a current carrying conductor can withstand for a given disconnection time. When a conductor line is superimposed against a protective device time / curve, where the line crosses the curve indicates the maximum disconnection time for that particular cable and insulation combination. As a general rule of thumb, if the fault line is to the right of the curve then the situation is acceptable.

- 1) Select **Fault Lines** from the menu to reveal the data input screen.
- 2) Select the type of protective device from the **Select protective device** list.
- 3) Select the Rating of the protective device by clicking on the up and down arrows.
- 4) Select the type of Conductor from the available **Conductor options**
- 5) Select the type of Insulation from the available **Insulation options**
- 6) Select the Size of cable from the **Cable Size** list.

If you wish to display disconnection time as well as a conductor fault line, then Input the fault current in Amperes. (This will automatically display the Fault current from the last calculation performed in Cablecalc for Windows). If this input is left blank then no disconnection time characteristics will be displayed.

Select **continue** to calculate and view the results on screen.

Clear

Use this menu option to clear all items from the graph.

The Conduit Utility

Cablecalc “Plus” for Windows Conduit size utility may be used to determine capacities of conduits using the method described in Appendix A “Cables capacities of conduit & trunking” of the guidance notes for the 16th Edition Wiring Regulations (Number 1 - Selection & Erection). The units used for the calculation are terms, as used by the British Electrical Systems Association (BESA) and are based upon diameter.

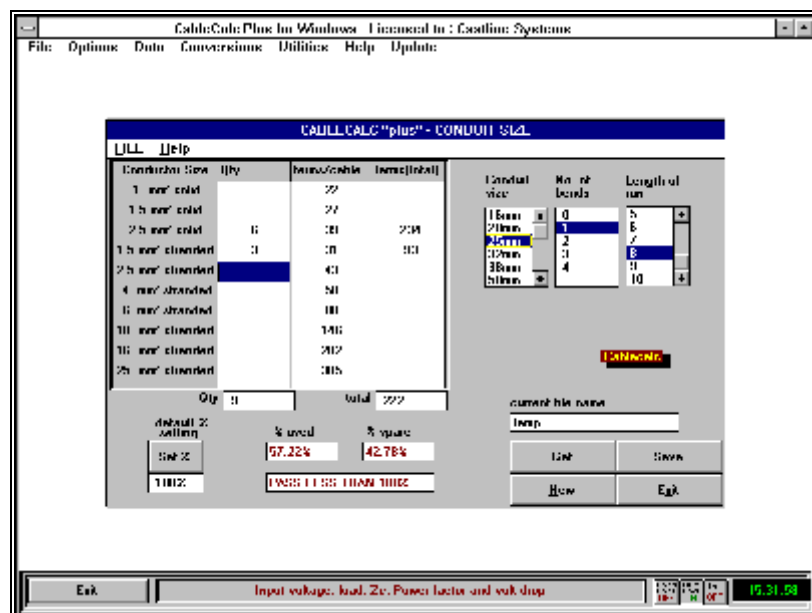

The menus

File

Save

Saves the current calculation as a *.con file.

Open

Loads and opens an existing file.

New

Creates a new file.

Print

Prints the current file data.

About

Displays an overview of Conduit Size

Exit

Exits Conduit and returns to the main Cablecalc for Windows screen.

Help

Getting Help

Displays a message on how to obtain help

Keys

Describes the short-cut keys

The following inputs may be performed in any order: -

Select the length of the conduit run from length of run list

Select the number of bends in the conduit run from the Number of bends list.

Select the size of conduit from the Conduit size list.

Input the number of cables for each relevant cable size in the data entry grid, the terms per cable and the total terms are automatically displayed in the adjacent grid cells.

Important To accept the quantity into the calculation you must either press the enter key or move to another grid cell using either the up or the down arrow keys

The totals are displayed beneath the grid for the number of cables (regardless of size and the number of terms).

Displays

The % used

Is the percentage of the conduit that is used, if this figure exceeds the predetermined criteria a FAIL message will appear.

The % spare

Is the percentage of the conduit that is not used, if this figure exceeds the predetermined criteria a FAIL message will appear.

Default % setting

The default setting is the percentage relative to the recommended maximum capacity permitted by the IEE regulations (This is regarded as 100%). The provision to change this figure is useful for providing space for future expansion or additions to the installation. i.e. a specification may require that all conduits have a free capacity of 25% for future expansion, in which case the default % would be set by the user to 75%. This will ensure that all conduits are filled to within the specified limits.

The buttons at the bottom of the conduit screen duplicate the menu options listed previously

The Trunking Utility

Cablecalc “Plus” for Windows Trunking size utility may be used to determine capacities of trunking using the method described in Appendix A “Cables capacities of conduit & trunking” of the guidance notes for the 16th Edition Wiring Regulations (Number 1 - Selection & Erection). The units used for the calculation are terms, as used by the British Electrical Systems Association (BESA) and are based upon diameter.

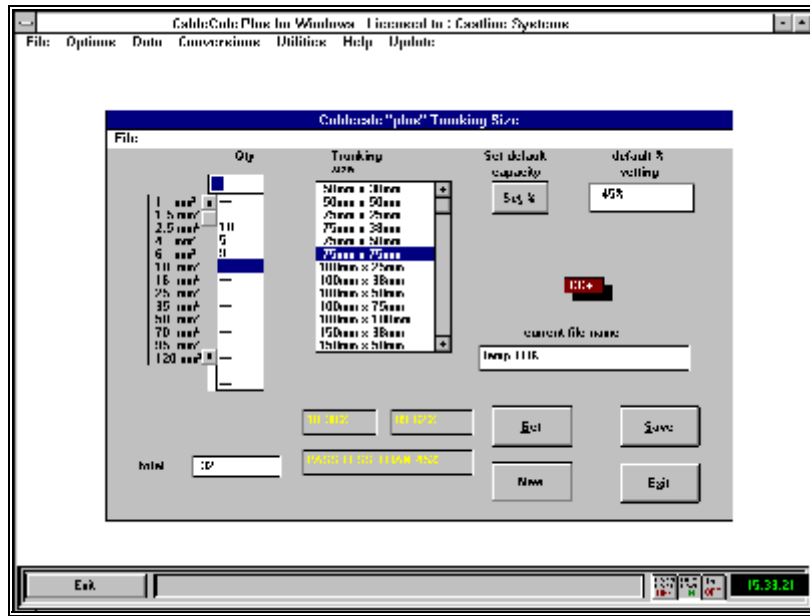

The menus

File

Save

Saves the current calculation as a *.trk file.

Open

Loads and opens an existing file.

New

Creates a new file.

Print

Prints the current file data.

About

Displays an overview of Trunking Size

Exit

Exits Trunking and returns to the main Cablecalc for Windows screen.

Help

To obtain on line help press the **F1** function key.

The following inputs may be performed in any order:-

Select the size of trunking from the Trunking size list.

Input the number of cables for each relevant cable size in the data entry grid.

The total number of cables is automatically displayed regardless of size in the total box.

Displays

The % used

Is the percentage of the trunking that is used, if this figure exceeds the predetermined criteria a FAIL message will appear.

The % spare

Is the percentage of the trunking that is not used, if this figure exceeds the predetermined criteria a FAIL message will appear.

Default % setting

The default setting is the percentage relative to the recommended maximum capacity permitted by the IEE regulations (This is regarded as 100%). The provision to change this figure is useful for providing space for future expansion or additions to the installation. i.e. a specification may require that all trunking runs have a free capacity of 25% for future expansion, in which case the default % would be set by the user to 75%. This will ensure that all trunking runs are filled to within the specified limits.

The buttons at the bottom of the trunking screen duplicate the menu options listed previously.

The Diversity Utility

Allowances for Diversity are determined using the method described in Appendix J “Maximum Demand and Diversity” of the guidance notes for the 16th Edition Wiring Regulations (Number 1 - Selection & Erection).

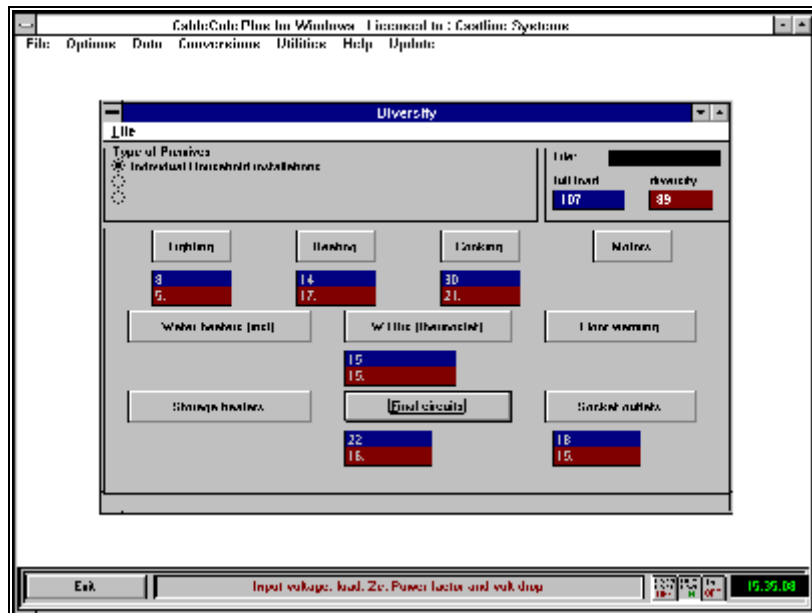

The menus

File

Save

Saves the current calculation as a *.dvy file.

Open

Loads and opens an existing file.

New

Creates a new file.

Print

Prints the current file data.

Exit

Exits Diversity and returns to the main Cablecalc for Windows screen.

About

Displays an overview of Diversity.

Help

To obtain on line help press the **F1** function key.

To calculate diversity first select the type of premises from the premises options: -

Individual Household installations

Small shop, stores, offices, business premises

Small hotels, boarding, guest houses etc.

The following inputs may be performed in any order: -

Lighting

Heating

Cooking
Motors
Water heaters (instantaneous)
Water heaters (thermostat)
Floor warming
Storage heaters
Final circuits
Socket outlets

Input the Load in Amperes for the relevant items, the full load current and the diversified current are automatically displayed in the totals boxes.

Trouble Shooting

Version

To find the version number of the programme on your computer select '**About**' from the '**Help**' drop down menu.

Where to look for answers

If your problem is of an electrical nature, such as a calculation that seems to be giving strange values or failing unnecessarily, examine the *Calculation Related Problems* below. Otherwise, if the computer just wont print, or you have other problems of this nature, refer to *Computer Related Problems*. If you are having problems in using the programme we recommend that you use the *Cablecalc for Windows Getting Started* featured earlier.

Computer Related Problems

The following covers possible problems of a computer nature that may be encountered when using *Cablecalc for Windows*, together with suggested solutions.

1. Some Laser printers may have difficulty printing this on-line manual often resulting in a memory error as well as it printing in three or more sections. *If this happens to you, you may need to change the settings on the printer in Windows. Try decreasing the setting marked resolution to 150 dpi (see your Windows manual for details on how to do this).*

NOTE: The manual may take up to ten minutes to print, including a large pause before the printer starts working. This is quite normal, and is not a problem with the software or your system. However, you should ensure that you have at least 4 Megabytes of free space on your hard disk to accommodate the temporary print file before starting to print.

2. When selecting fonts for the calculation printout always run a **Print Preview** before deciding on a font to use because some fonts produce unexpected effects (and can be unreadable, if a font such as Symbol or Wingdings is selected!). If in doubt, stick to the standard two readable fonts that are supplied with Windows, Times New Roman and Arial.
3. If the software prints a demonstration Watermark across all the printouts this normally means that the software is either a demonstration version of the programme or that it is the full version but has been incorrectly installed. If this happens (and you are NOT running a demonstration copy) check at the top of the screen to see if you are running the correct

level. If the level is displayed as 'Level 0' then the software has been incorrectly installed. In the event of this happening to you, in the first case try re-installing the software using the correct method. If this still does not cure the problem, contact Castline Systems.

Operation problems

Error codes

5	Illegal function call	55	File already open
6	Overflow	57	Device I/O error
7	Out of memory	58	File already exists
9	Subscript out of range	61	Disk full
11	Division by zero	67	Too many files
13	Type mismatch	68	Device unavailable
28	Out of stack space	70	Permission denied
48	Error in loading DLL	71	Disk not ready
51	Internal error	74	Cannot rename with different drive
52	Bad file name or number	75	Path / File access error
53	File not found	76	Path not found
54	Bad file mode		

Most of the above errors are self evident but care must be taken to input the correct data, omitting data may cause the programme to error.

Error numbers 5 to 51 are mathematical / data errors

Error numbers 52 to 76 are disk / file / path errors

Printer Errors should be trapped by the operating system

Glossary of Terms

NICEIC

National
Inspection
Council for
Electrical
Installation
Contracting

P.F.

Power Factor

Psc

Prospective
Short Circuit
Current

Ze

Phase earth
loop
impedance
from the
source of
energy to the
end of a final
circuit

Index

A

Ambient Temperature 13

B

Bitmap Image..... 39

Buttons..... 32

C

Cable Calculator 10, 12, 14, 32, 33

Cable Size 27

Cables 20

Calculate and Save a Cable 17, 36

Calculation Errors 12, 27

Calculation method 24

Calculation related problems 28

Computer Related Problems 49

Correction Factor 24

Create Distribution board 14

Create Project file..... 35

D

Discrimination 41

Distribution Board 7, 33, 35, 36

Diversity 19

Diversity Utility 45

E

Elite 8

Error codes..... 51

F

Fail..... 12, 28, 43, 45

Fault Lines 41

Formulae and Conversion..... 15

G

Grouping (Cg)..... 23

H

Help 10

Hint Button 12

I

Impedance..... 28

Index Tabs 10

Installation 9

L

Laser Printers 49

Lighting Circuit..... 8, 18

Load..... 17, 18, 28, 47

M

Menus 33

Motor 19

Multiplier 22

O

Operation problems 51

Overload / short circuit protection 21

P

Plus 7

Power Factor..... 14, 53

Print Graph 39

Print Preview 12, 27, 49

Printing Reports 11

Professional..... 8

Project Default Values..... 13

Project Manager 11, 12, 13, 14, 31, 34, 37

Projects A Beginners Guide 34

R

Radial Circuit..... 17

Resolution..... 9, 49

Ring Circuit 18

S

Sample File 12

Save a circuit within the Distribution board
file. 36

Saving Your Work 11

screen resolution 9

Select CPC..... 25

Select Protective Device..... 21

Set Defaults..... 10, 17

Setting up a Project File 13

Setting Your Printer 11

Short Circuit Current..... 14, 53

Star Delta circuit 18

Starting a Calculation 10

Starting Cablecalc 10

Sub main..... 18

Supplied from 14

Supply Details..... 14

Supply Impedance.....	13
Supply Voltage	13

T

Tab 1 - Supply	17
Tab 2 - Cables.....	20
Tab 3 - Protection	21
Tab 4 – Derating	23
Tab 5 - CPC Details	25
Tab 6 - Calculate.....	27
Temperature (Ca).....	23
The Cable Calculator	17
The Conduit Utility	42
The Project Manager.....	31
The Time Curve Utility.....	39
Thermal insulation (Ci).....	23
To Calculate a Cable	36
To Calculate a Sub Main Cable.....	18, 37
Trouble Shooting	49
Trunking Utility	44
Type of Circuit.....	17, 21

U

User Defaults	17
Utilities.....	39

V

Volt Drop	13, 27, 29
-----------------	------------